



PPS 4/2 TWO-CHIP MICROCOMPUTER SYSTEM

Rockwell introduces two new microcomputer circuit devices which provide a flexible system for cost sensitive applications. The two circuits comprise a CPU chip and a combination Memory and I/O chip. These chips may be used as a complete two chip microprocessor or with other Rockwell circuits of the PPS-4 family to provide a broad spectrum of system functions at lower costs than previously attainable.

FEATURES

PPS4 2 CPU CIRCUIT

- Self-contained Clock
- PPS-4 Instruction Set
- Expanded I/O Using Discrete I/O Commands
- Direct LED Segment or Fluorescent Display Compatibility
- PPS-4 Bus System Compatibility
- 5 Microsecond Cycle Time
- 100 pf Bus Drive Capability

PPS4/2 MEMORY/I/O SYSTEM CIRCUIT:

- 2048 x 8 Read-only Program Memory (ROM)
- 128 x 4 Data Memory (RAM)
- 16 One-bit Input:Output Ports
- Option of Using Two Memory/I/O Circuits per System

SYSTEM DESCRIPTION

The PPS-4 2 System has been designed to provide a basic two circuit microcomputer which is optimized for applications requiring low cost and high performance. The two circuits provide all the computing power and applications flexibility which would require five or more of the conventional PPS-4 circuits to implement. The PPS-4:2 may be expanded to more complex applications by using any of the large family of PPS-4 circuits so that the cost of more complex systems may be reduced. The basic PPS-4:2 system is shown in Figure 1.

PPS-4/2 CPU (PN 11660)

The PPS-4 2 CPU uses an identical instruction set as the PPS-4 CPU but includes the clock generator function within the CPU circuit as well. When a conventional NTSC color TV crystal (3.579545 MHz) is connected to the XTAL I and XTAL O pins and the VCLOCK pin is connected to VDD, the CPU circuit will generate the 198.864 KHz system clock signals. These signals, A and \bar{B} , are used internally in the CPU and are made available to all of the PPS-4/2 and PPS-4 circuits in the system.

An additional feature in the PPS-4:2 CPU is an expanded discrete output capability. This capability is achieved by using the same instruction (DOA) as in the PPS-4 CPU but providing more I/O control. In the PPS-4 the DOA instruction causes the contents of the accumulator (A) to be transferred to an output buffer and then retained until another DOA instruction is executed. The contents of this buffer controls the output drivers. In the PPS-4 2 CPU this same function is performed but, additionally, the contents of the X register are transferred to a similar second set of buffers and drivers (DIO) so that the DOA instruction causes 8 bits to be available to external devices.

u

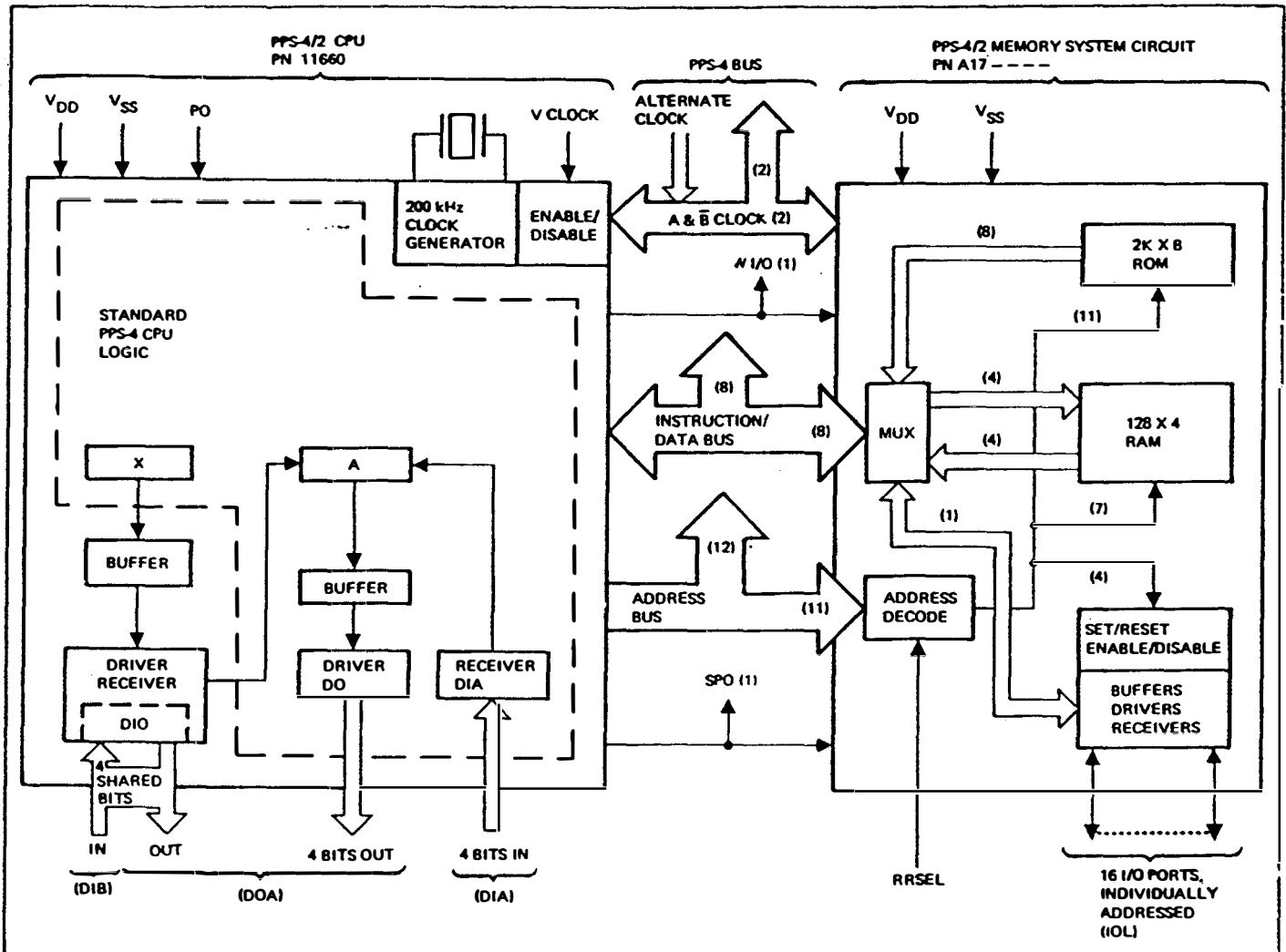

Figure 1. PPS-4/2 Two Chip Minimum Configuration

PPS-4/2 CPU (PN 11660) Continued

The discrete input commands functionally are identical in both CPU's but in the PPS-4/2 the DIB input pins are shared with the output lines loaded from the X register. The output discrete signals are all supplied from drivers which are open drain MOS transistors to VSS. If the DIO pins are being used for inputs, then the DIB instruction has the potential of providing a "masked" input if the external circuits are properly designed. The masking may be accomplished by outputting zeros from the X register with the DOA command. Where the zeros occur, the input lines will be clamped to VSS. Consequently, when the DIB instruction is executed, only the unmasked bits are loaded into the accumulator. When used in this mode, the external circuits must be designed to limit the current so that no damage can occur when the signal is tied to VSS. When all four bits are to be read, no special circuit considerations are necessary if, prior to the DIB instruction, all "one's" are output from the X register by a DOA command.

The PPS-4/2 CPU automatically floats all output lines when power is turned on. Functionally there are no other differences between the PPS-4 and the PPS-4/2 CPU's. However, the PPS-4/2 CPU also has the capability of directly driving low-power LED display segments. Fluorescent displays can also be driven if the system includes the appropriate power supply for the higher voltage display.

PPS-4/2 MEMORY/IO CIRCUIT (PN A17---)

The Memory/IO Circuit, also shown in simplified form in Figure 1, has a full 2K bytes of program storage in ROM and 128 x 4-bit words of data storage in RAM. This circuit also includes an input/output capability which allows the individual control of 16 one-bit I/O ports. All of the functions in the Memory/IO Circuit make common usage of the address decoding circuitry.

Read-Only-Memory (ROM) Section

The Read-Only-Memory is addressed in the same manner as the PPS-4 during phase 2 time, by a combination of the eleven address bits brought into the circuit and the matching of either a "1" or a "0" on the ROM/RAM Select (RRSEL) pin and an internal code established in the ROM pattern. In effect the RRSEL signal may be used as a twelfth address bit or may be used to "bank select" additional ROM's beyond the 4K direct addressing capability of the 12-bit address bus.

Data Memory (RAM) Section

The Data Memory is addressed during phase 4 time. In this circuit the state of the RRSEL during phase 4, the internal code established during fabrication, and the A/B 8 signal will establish if the RAM in the memory circuit is being accessed. Both the A/B 8 signal and the RRSEL signal must match the internal code to select the RAM. The lower 7-bits of the address will then establish which 4-bit word is being accessed and the W/I/O line performs the same function as in the PPS-4 to signal that a read or a read and simultaneous write is being commanded.

Input/Output Section

In the Memory/I/O Circuit, the input/output section is commanded by the same technique used by all PPS-4 I/O devices. First an IOL instruction is executed in the CPU which causes the W/I/O line to signal all I/O devices in the system that the next instruction byte contains a device identification (4-bits) and the specific command to be executed (4-bits). The IOL instruction, via the W/I/O line, also tells the RAM to stay off the data bus so that the input/output data may be transmitted.

In this circuit the I/O section may be encoded during fabrication to be identified as device 0, 2, 4, or 6 so that any conflict with other I/O device addresses used in the specific system may be avoided.

There are two basic instructions interpreted by the I/O section, Select Enable Status (SES) and Select Output Status (SOS), but the I/O section also makes use of information from the accumulator and from the address bus to actually generate a total of 64 unique instructions.

The address logic in the device decodes the lower 6-bits of the address bus and makes use of the lowest 16 unique addresses to address I/O lines 0 through 15. Consequently, the lower two-bits in the BM portion of the data address register must be zero. Then the BL portion will identify the I/O port.

Each port has a driver similar to the drivers on the PPS-4/2 CPU which consists of an open drain to the VSS MOS transistor and a holding flip-flop. The addressed holding flip-flop is set to the same state as the most significant bit in the accumulator if a Select Output Status command is executed. Also whenever any I/O command is executed, the state of the signal on the addressed I/O port at the prior bit time causes the most significant bit in the accumulator to be set to the same state simultaneous with the output function.

The second basic instruction, Select Enable Status (SES), controls all 16 I/O ports simultaneously. When SES is executed, if the most significant bit in the accumulator is a zero all outputs are disabled (floated), and conversely, if it is a one all of the outputs are made available from the holding flip-flops. With this instruction, as with the SOS instruction, the status of the port addressed by BL is loaded into the accumulator. All of the input-output functions in the Memory/I/O Circuit are summarized in Table 1.

The SPO signal generated when power comes on causes the enable flip-flop to be set to zero so that all 16 I/O ports are floated. The individual holding flip-flops are not set automatically.

POTENTIAL APPLICATIONS

The basic PPS-4/2 two circuit system may be used for many applications without requiring any other PPS-4 devices and minimal amounts of external hardware. The 16-ports from the Memory System Circuit may be used as strobe lines for a keyboard and the DIA, or DIA and DIB, inputs can be used for up to 64 or 128 key keyboards. The 8-bits obtained from a DOA instruction may be used to directly drive a 7- or 8-segment display and the strobe signals can also be derived from the same outputs as were used for the keyboard strobing. A block diagram of a 16-digit direct drive display and 64-key keyboard system is shown in Figure 2. In fluorescent displays using the tubes as pull up resistors, no other circuit devices are required. LED displays may require a current sink transistor for each digit. Other configurations are possible. For instance if the DIA and DIB inputs are used for a 128-key keyboard, the 4-bits of output obtained from the DO lines could drive a BCD-to-7 segment decoder. Also, a cash register-type-printer could be operated by using the 16-output lines, controlled by the SES instruction, to signal which print solenoids should be activated to print all of the characters in a line while timing and output control signals are provided from the PPS-4/2 CPU.

Many options are possible. One option would be to use the basic PPS-4/2 circuit input/output for a keyboard display function. Another option would be to use a printer controller circuit to control the printer. This is illustrated in the block diagram shown in Figure 3. Another option would be to use a keyboard printer circuit and generate the display function in the microcomputer set. Still another option would be to use a general purpose keyboard display circuit and control the printer from software and the basic I/O. The basic I/O is flexible enough so that the PPS-4/2 two circuit system can provide the capabilities for sophisticated controllers for a variety of industrial applications. Sequencers and sophisticated timing systems, set point controllers with complex control functions, automotive controllers, electronic games, etc., all provide potential areas of application for the low cost PPS-4/2 System.

TABLE 1. I/O SECTION INSTRUCTIONS

Mnemonic	Command Name	I/O Bus 8 7 6 5 4 3 2 1	Accumulator A4 A3 A2 A1	Description
SES	Select Enable Status	0 S S 0 X X X 0	1 X X X	Enable All Outputs (Enable F/F ← 1) Accumulator ← 1XXX if I/O(00BL)=1 Accumulator ← 0XXX if I/O(00BL)=0
SES	Select Enable Status	0 S S 0 X X X 0	0 X X X	Disable All Outputs (Enable F/F ← 0) Accumulator ← 1XXX if I/O(00BL)=1 Accumulator ← 0XXX if I/O(00BL)=0
SOS	Select Output Status	0 S S 0 X X X 1	1 X X X	I/O(00BL) F/F ← 1 Accumulator ← 1XXX Accumulator ← 0XXX if I/O(00BL)=0
SOS	Select Output Status	0 S S 0 X X X 1	0 X X X	I/O(00BL) F/F ← 0 Accumulator ← 1XXX if I/O(00BL)=1 Accumulator ← 0XXX if I/O(00BL)=0

SYSTEM INTERFACE

The timing and bus characteristics of the PPS-4/2 System are identical to the PPS-4 System with a reduced capability in the total number of circuits which can be driven from the CPU. Capability is provided for driving up to ten PPS circuits. The signals for each of the circuits with their pin numbers are identified in Tables 2 and 3. All discrete output signals have approximately twice e current drive capability of the PPS-4 CPU.

The PPS-4/2 System is thoroughly compatible with all standard PPS-4 devices including the ROM, RAM, EEROM, Bus Interface (BI), RAM Interface, and complete family of I/O devices.

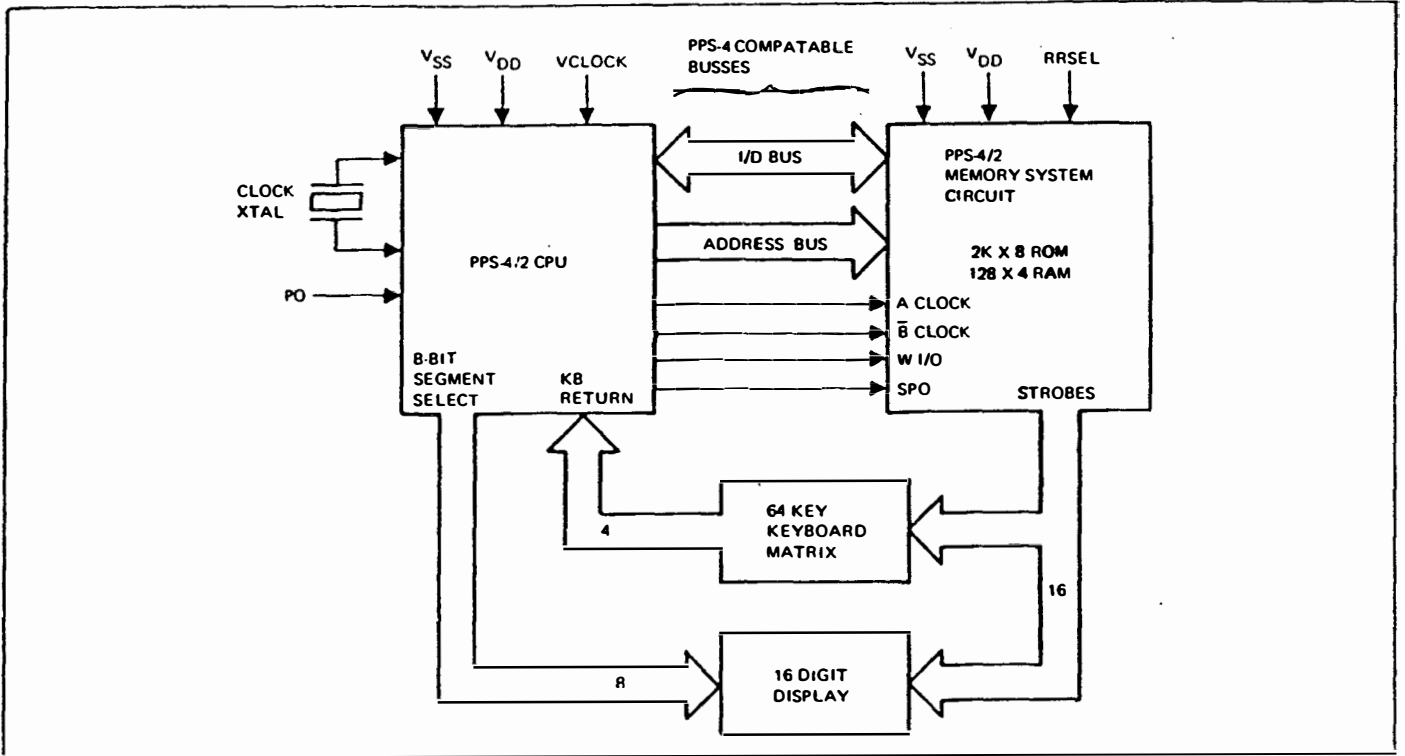

Figure 2. Basic PPS-4/2 System Driving Keyboard/Display System

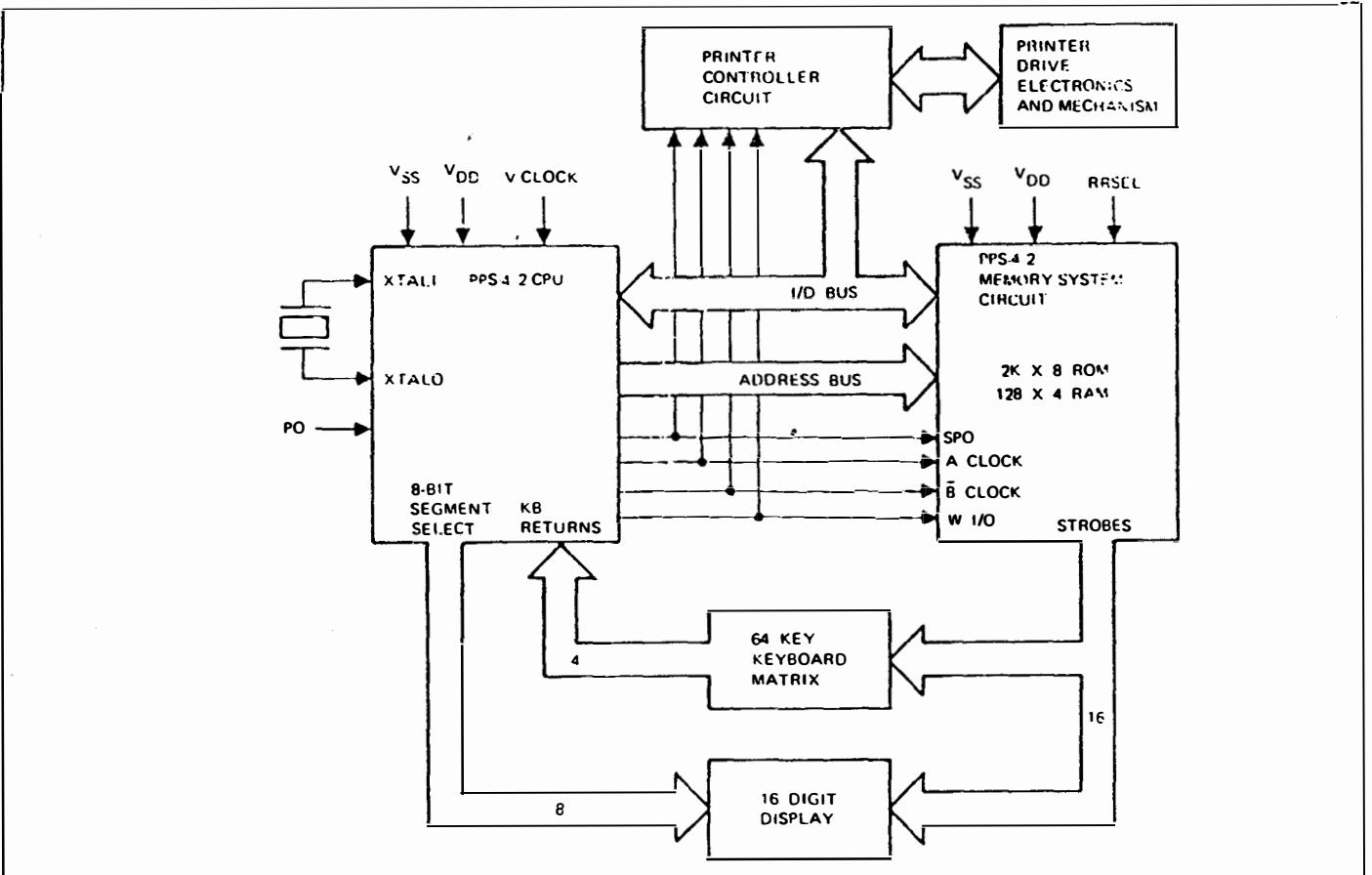

Figure 3. Low Cost Cash Register Block Diagram

TABLE 2. PPS-4/2 CPU SIGNALS(PN11660)

TABLE 3. MEMORY/I/O SYSTEM CIRCUIT SIGNALS (PN A17--)

Pin No	Signal Name	Function	Pin No	Signal Name	Function
39	VDD	System Power	28	A/B1	Address Bus
20	VSS	System Power	29	A/B2	Address Bus
22	PO	Power On Reset	30	A/B3	Address Bus
21	SPO	Synchronized Power On	31	A/B4	Address Bus
14	W/O	Write Command and I/O Enable	32	A/B5	Address Bus
16	CLKA	System Clock	33	A/B6	Address Bus
15	CLK \bar{B}	System Clock	34	A/B7	Address Bus
17	VCLK	Clock Enable/Disable	20	A/B8	Address Bus
19	XTAL I	Crystal In	23	A/B9	Address Bus
18	XTAL O	Crystal Out	21	A/B10	Address Bus
			24	A/B11	Address Bus
10	I/D1	Instruction/Data Bus	16	I/D1	Instruction Data Bus
12	I/D2	Instruction/Data Bus	17	I/D2	Instruction Data Bus
13	I/D3	Instruction/Data Bus	18	I/D3	Instruction Data Bus
11	I/D4	Instruction/Data Bus	19	I/D4	Instruction Data Bus
6	I/D5	Instruction/Data Bus	15	I/D5	Instruction Data Bus
7	I/D6	Instruction/Data Bus	10	I/D6	Instruction Data Bus
8	I/D7	Instruction/Data Bus	11	I/D7	Instruction Data Bus
9	I/D8	Instruction/Data Bus	12	I/D8	Instruction Data Bus
27	A/B12	Address Bus	26	VDD	Power
28	A/B11	Address Bus	22	VSS	Power
29	A/B10	Address Bus	9	SPO	Synchronized Power On
30	A/B9	Address Bus	27	CLK A	System Clock
31	A/B8	Address Bus	25	CLK \bar{B}	System Clock
32	A/B7	Address Bus	8	I/O 0	Input/Output Port
33	A/B6	Address Bus	7	I/O 1	Input/Output Port
34	A/B5	Address Bus	6	I/O 2	Input/Output Port
35	A/B4	Address Bus	5	I/O 3	Input/Output Port
36	A/B3	Address Bus	4	I/O 4	Input/Output Port
37	A/B2	Address Bus	3	I/O 5	Input/Output Port
38	A/B1	Address Bus	2	I/O 6	Input/Output Port
2	DIA4	Discrete Input Group A	1	I/O 7	Input/Output Port
3	DIA3	Discrete Input Group A	42	I/O 8	Input/Output Port
4	DIA2	Discrete Input Group A	41	I/O 9	Input/Output Port
5	DIA1	Discrete Input Group A	40	I/O 10	Input/Output Port
26	DO4	Discrete Output	39	I/O 11	Input/Output Port
25	DO3	Discrete Output	38	I/O 12	Input/Output Port
24	DO2	Discrete Output	37	I/O 13	Input/Output Port
23	DO1	Discrete Output	36	I/O 14	Input/Output Port
1	DIO4	Discrete Input/Output	35	I/O 15	Input/Output Port
42	DIO3	Discrete Input/Output	13	W/O	Write Command and I/O Enable
41	DIO2	Discrete Input/Output	14	RRSEL	ROM/RAM Select
	DIO1	Discrete Input/Output			

SYSTEM SUPPORT

Since the PPS-4/2 software is identical to that of the PPS-4, all of the software development aids on the GE, TYMESHARE, and IBM TSO timesharing systems are directly applicable to the PPS-4/2 System. The existing PPS-4MP Assembler can be used for assembly and program debugging functions which are independent of the I/O. An evaluation board for the PPS-4.2 System which will replace the evaluation board in the PPS-4MP Assembler will be available to allow the same unit to be used for a system debugging and development. The evaluation board will also be made available to be used in prototype development.

AVAILABILITY

Engineering samples of the PPS-4/2 System will be available in early fall of 1975. The evaluation boards will be available in late fall of 1975 and full production quantities will be available starting in early 1976. Contact Rockwell International Microelectronic Device Division for further information.

SAMPLE INPUT/OUTPUT PROGRAMS

The following sample routines show the philosophy of using the PPS-4/2 System input/output capability to control printers and displays.

PARALLEL PRINTER DRIVER ROUTINE (DRUM TYPE PRINTER)

Start with printface row number in "X"		Data to be output is in "PRTDAT"
	LDI 0	
	IOL SES	(DISABLE OUTPUTS)
	.	
	.	
	.	
	LB PRIDAT	OBTAIN 1ST DIGIT
	LAX	
	EOR	COMPARE WITH PRINTFACE ROW
	SKZ	
	LDI 8	NO MATCH
	LDI 0	MATCH SO ARM HAMMER
	IOL SOS	VIA IOL
	.	
	.	
	.	
	DECB	SEQUENCE TO NEXT DIGIT
	T A	
	.	
	.	
	.	
	LDI 8	AT PROPER TIME PRINT
	IOL SES	(ENABLE OUTPUTS)
	.	
	.	
	.	
	RET	

NOTE

TOTAL TIME TO SET UP 16 COLUMNS

$$IS 16 \times 9 \times 5\mu\text{SEC} = 720\mu\text{SEC}$$

DISPLAY DRIVER ROUTINE

Segment pattern previously determined and stored in RAM at this point.

LDI 15	ALL ONES TO A AND X
LXA	
DOA	A ← TURN SEGMENTS <u>OFF</u>
DECB	POINT TO LAST STROBE
LDI 8	
IOL SOS	B ← TURN LAST STROBE <u>OFF</u>
.	
.	
.	
INCB	POINT TO NEW STROBE
LDI 0	
IOL SOS	C ← TURN NEW STROBE <u>ON</u>
.	
.	
.	
LB SEG	
EXD	LOAD MOST SIGNIFICANT 4 BITS
LXA	INTO X
LD	LOAD LEAST SIG 4-BITS IN A
DOA	D ← TURN NEW SEGMENT PATTERN <u>ON</u>

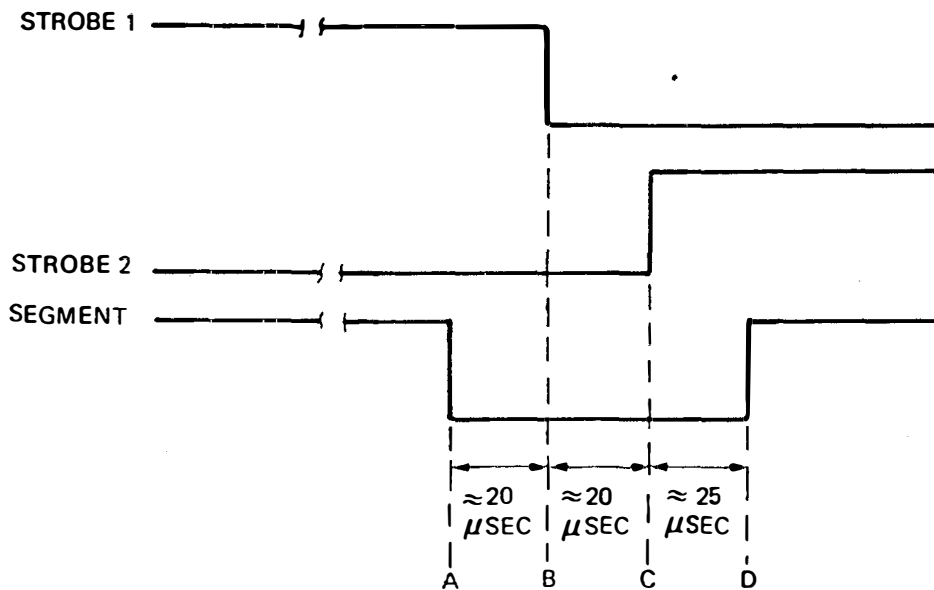

PPS SOFTWARE SEGMENT DECODING

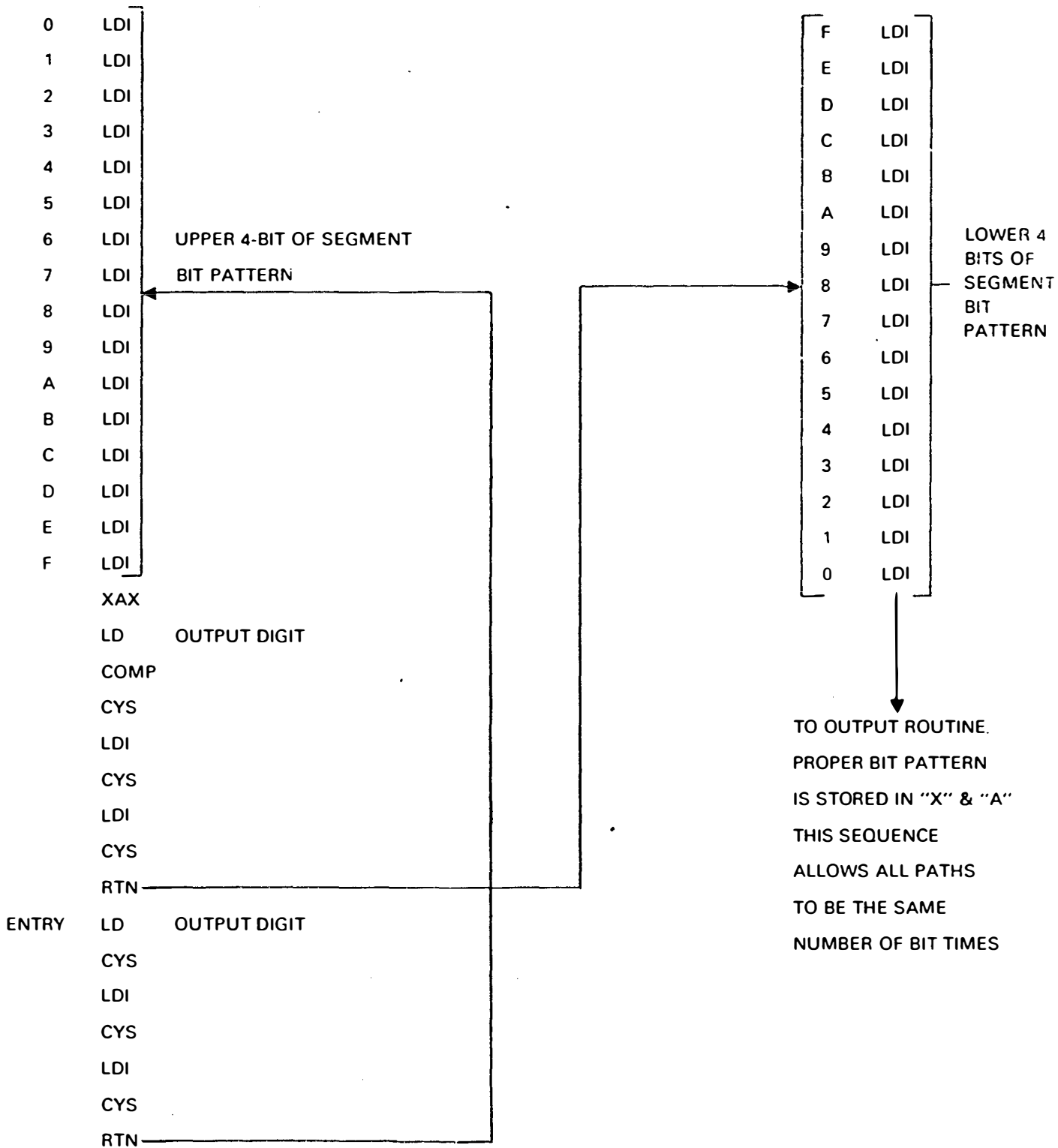

NOTICE

Rockwell International reserves the right to change this product and its specifications at any time without notice to improve its design or performance.

No responsibility is assumed by Rockwell International for use of this information; nor for any infringement of patents or other rights of third parties which may result from the use of this information.

For specific detail information on this device or for information on any of our other advanced microelectronic devices, please contact the nearest Rockwell International Microelectronic Device Division office.

LOCAL REPRESENTATIVE

REGIONAL SALES OFFICES

EASTERN REGIONAL MANAGER

JIM PIERCE
Rt. 2 Box 825
Riverhead, N.Y. 11901
Phone: 516/979-0183

JAPAN SALES MANAGER

SHIGE MURASE
Rockwell International Overseas Corp.
Ichiban-cho Central Bldg.
22-1 Ichiban-cho, Chiyoda-ku
Tokyo 102, Japan
Phone: 265-8808



**Rockwell
International**
Microelectronic Device Division

EUROPEAN SALES MANAGER

ANDRE KOBEL
Rockwell International GmbH
Microelectronic Device Division
Frauenhoferstrasse 11
D-80333 Munchen-Martinsried
Germany
Phone: 8599575

S. EASTERN REGIONAL MANAGER

RON JANSSEN
3500 McCall Place
Atlanta, Ga. 30340
Phone: 404/458-2265

CENTRAL REGIONAL MANAGER

JIM SMITH
2855 Coolidge Road, Suite 101
Troy, Mich. 48064
Phone: 313/435-1638

MIDWEST REGIONAL MANAGER

ALLAN CAREY
2620 E. Higgins Road, Suite 200-13
Elk Grove Village, Il. 60007
Phone: 312/439-1713

WESTERN REGIONAL MANAGER

BILL TRELEAVEN
Box 3669
Anaheim, Ca. 92803
Phone: 714/632-3698